



## BRACKET BRIDGE FOR CONCRETE-WOOD JOINTING POLES

ОБОЙМА ДЛЯ БЕТОННОЙ СТОЙКИ

COLLIER

Designed for transition-connection of wooden poles to concrete stands. Usually galvanized or on request hot-dip galvanized.

Применяется для крепления деревянного столба на бетонных стойках. Защита от коррозии выполнена гальваническим цинкованием.

On l'utilise pour fixer la pile en bois pour les pieds de béton. La protection de la corrosion est faite par zink galvanique.

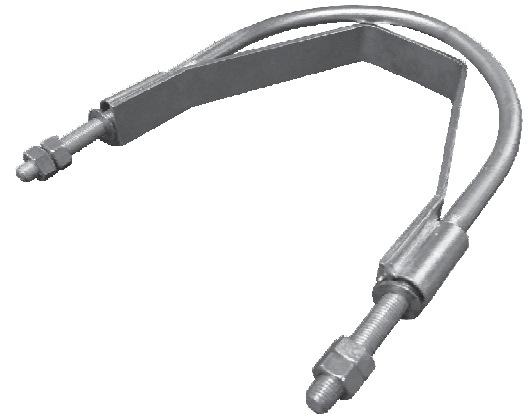
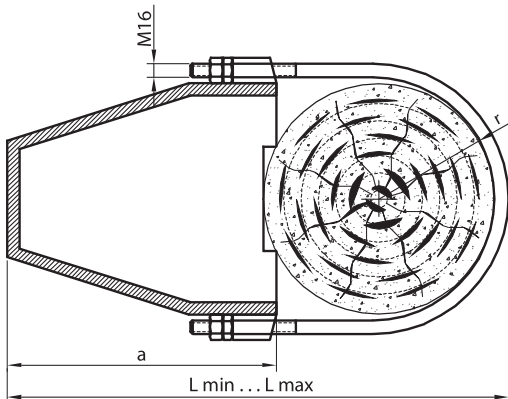

MATERIAL: STEEL  
МАТЕРИАЛ: СТАЛЬ  
MATERIAL: ACIER

No. п/п N. Ord.	Screw Винта Voulon	Code Код (номер) Code	Type Тип Type	Dimension (mm) Размер (мм) Dimension (mm)				Packing Упаковка Emballage	Weight Вес Poids
				a	r	L min	L max		
1	M16	P90-04-01	130 - 140	198	133	335	475	-/5	2 523.00

## STEEL CABLE CLAMP

ЗАЖИМЫ СТАЛЬНОГО ТРОСА

SERRE-CÂBLES À ÉTRIER

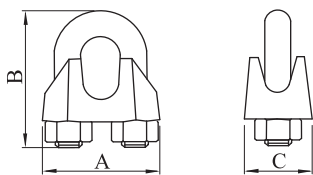

MATERIAL: STEEL  
МАТЕРИАЛ: СТАЛЬ  
MATERIAL: ACIER



No. п/п N. Ord.	Cable cross-section Сечение провода Section	Code Код (номер) Code	Type Тип Type	Dimension (mm) Размер (мм) Dimension (mm)			Packing Упаковка Emballage	Weight Вес Poids
				a	b	c		
1	5	P93-03-08	5	22	24	10	-/100	10.36
2	6.5	P93-03-09	6.5	25	28	12	-/100	16.47
3	8	P93-03-10	8	30	34	14	-/100	28.00
4	10	P93-03-11	10	35	42	20	-/100	57.65
5	11	P93-03-12	11	37	44	20	-/100	63.85
6	13	P93-03-13	13	43	55	25	-/100	115.94
7	14	P93-03-14	14	45	57	25	-/100	125.74
8	16	P93-03-15	16	52	63	28	-/50	179.86
9	19	P93-03-16	19	58	75	32	-/50	272.95
10	22	P93-03-17	22	64	85	35	-/50	373.34
11	26	P93-03-18	26	68	95	38	-/50	481.34