

CODE: P800604
Item: Suspension clamp PS1500

PRODUCT TECHNICAL SPECIFICATION

Description: Clamp is designed for suspension of messenger lines of overhead ABC cables to poles or walls by hanging on standard hooks and brackets. Mostly, this clamp is used for suspension of the ABC cables on pole.

Cable cross-sections: 1x(35-95) mm² (ABC cable)

Cable diameter: 1x(9.3-16.3) mm

SMFL: 12 kN



Dimensions

a [mm] 27 mm
b [mm] 100 mm
c [mm] 12 mm
d [mm] 38 mm
L [mm] 140 mm

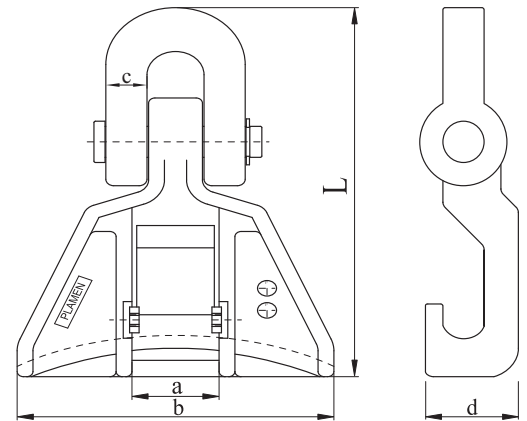

Other characteristics

Body: UV Polyamide
Movable link: UV Polyamide
Required tools: No tools required.

Marking: PLAMEN, 35-95[□], PS1500, production date

Standard: EN 50483-3, EN 61284, NFC33-041

Packing

Product weight: 180.00g per piece
Bag packing: - pcs
Box packing: 40 pcs
Box BRUTO weight: 7.70 kg

